

# INOX FILTER HOUSING

## EFH-SBR

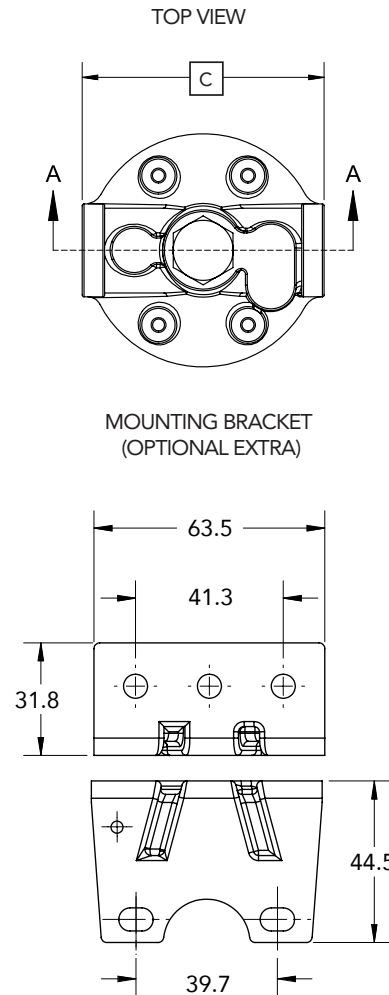
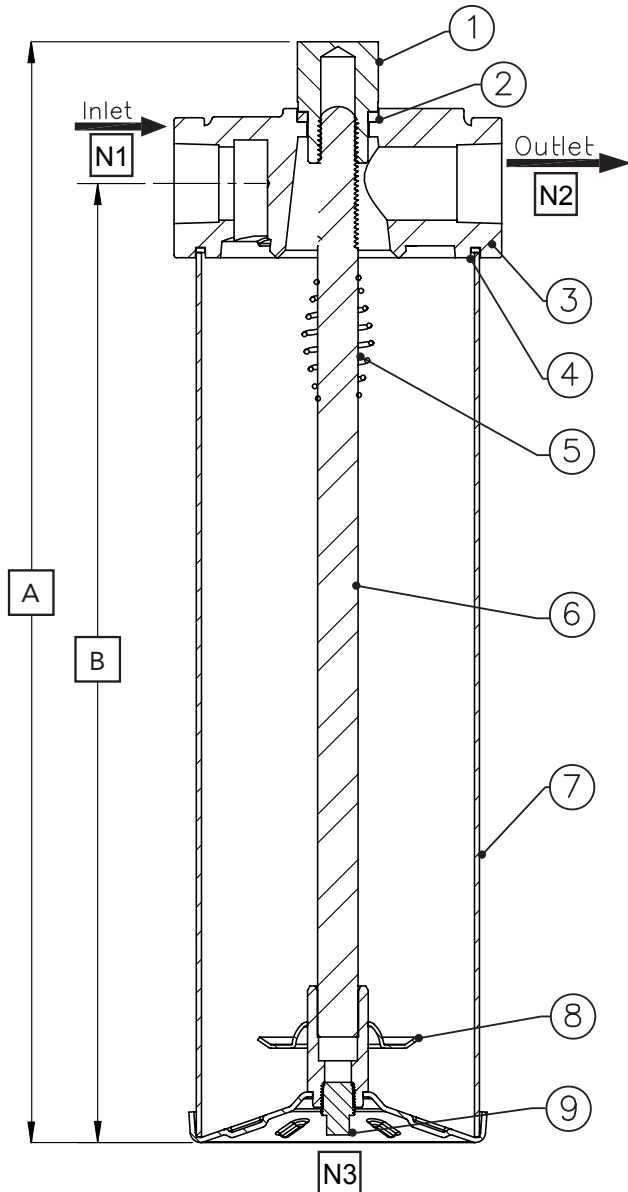

Dimensions				
Product Code	To Accommodate Filter Qty x Length	A mm	B mm	C mm
EFH-SBR-10	1 x 10"	346	301	103
EFH-SBR-20	1 x 20"	606	562	103
EFH-SBR-30	1 x 30"	860	816	103

Port Details		
No.	Type	Size
N1	Inlet	1/2", 3/4", 1" BSPT-F
N2	Outlet	1/2", 3/4", 1" BSPT-F
N3	Drain	1/4" FNPT

Components					
No.	Name	Material	No.	Name	Material
1	Top Nut	316	6	Centring Rod	316
2	Top Nut Seal	EPDM	7	Body	316L
3	Head	316L	8	Cartridge Seal Plate	316
4	Seal	EPDM	9	Drain Plug	316
5	Spring	316			

Technical Information	Maximum Operating Temperature	135°C
	<ul style="list-style-type: none"> <li>• Drain Port comes fitted with PTFE wrapped 316L plug</li> <li>• All dimensions are approximate</li> </ul>	Design Pressure